

Colonne

Kolomkast - Column - Hoshschrank



Pour les conditions de garantie, précautions d'usage avant montage, conseils d'entretien, règles élémentaires d'utilisation se référer GUIDE DE MONTAGE ET D'ENTRETIEN EUROPACK 591185-IM00348 ou 591190-IM00349

A consulter et à garder sans limite de temps

For Guarantee terms, precautions for use before assembly, maintenance tips and basic precautions for use, please consult the assembly and maintenance guide.

















Please read and keep indefinitely

Voor de garantievoorwaarden, voorzorgsmaatregelen voor de montage, onderhoudsadviezen en de basisregels voor gebruik gelieve de montage- en onderhoudshandleiding te raadplegen.

Om te raadplegen en voor onbepaalde tijd te bewaren

Für die Garantiebedingungen, Vorsichtsmassnahmen vor der Montage, Pflegehinweise und Grundlegende Regeln für die Verwendung bitte die Montage- und Pflegeanleitung aufmerksam lesen.

Bitte aufmerksam lesen und unbegrenzt aufbewahren

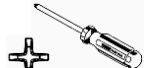
A  X3	B  X16	C  X4	D  X16	E  X1	F  X2	G  X8	H  X1	I  X1
J  X1	K  X1	L  X2	M  X8	N  X1	O  X1			
								

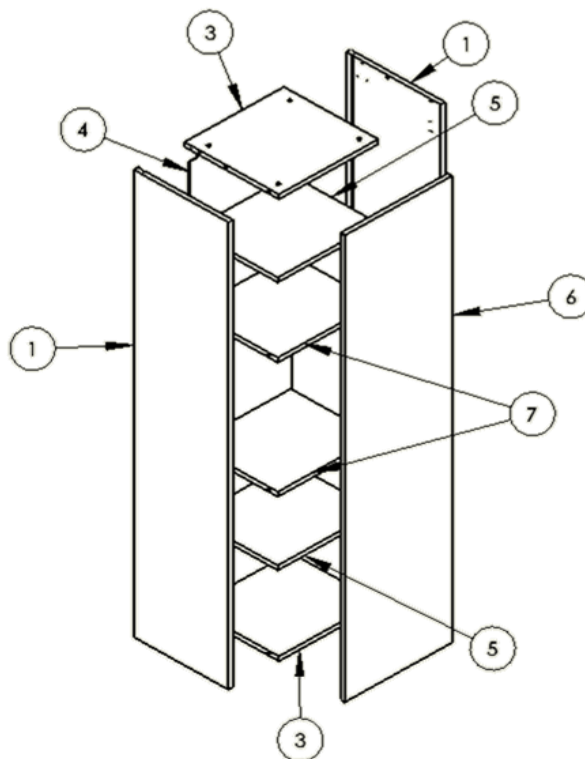
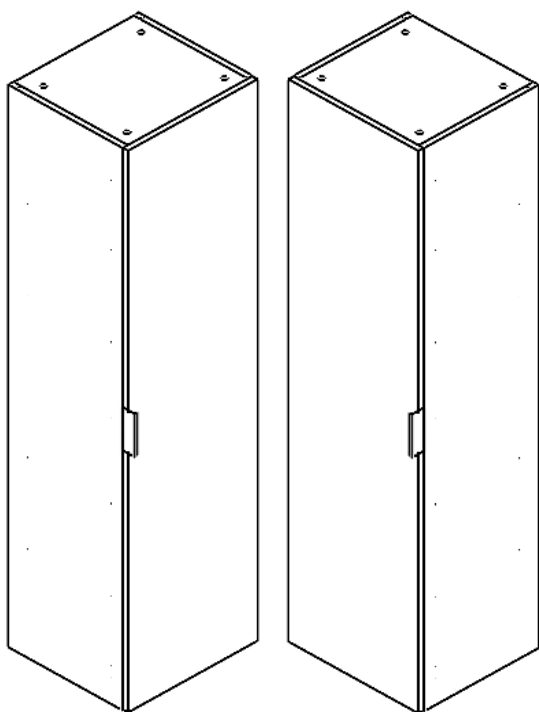

- (F) FIXATIONS**
Les fixations à utiliser sont en fonctions du mur;elles ne sont pas livrées avec le meuble.
- (B) BEVESTIGINGEN**
De te gebruiken schroeven en pluggen zijn afhankelijk van de muur waarop het meubel wordt aangebracht en worden derhalve niet meegeleverd.
- (NL) FIXATIONS**
The fixations to use depend of the type of support (wall) ; they are not delivered with the furniture.
- (GB) BEFESTIGUNGEN**
Die zu verwendenden Befestigungen hängen von Iher Wand ab;Sie sind nicht im Lieferumfang des Möbelstücks enthalten
Eine unsachgemäße Befestigung der Wandbefestigung kann zur Ablösung der Schränke aus der Wand führen. Benutzen Sie unbedingt Dübel, die in Verbindung mit dem Wandmaterial die Tragfähigkeit sicherstellen. Sollten Sie unsicher sein, welchen Typ Dübel und Schrauben Sie benötigen, fragen Sie bitte beim Fachhandel nach.

Ø6 mm

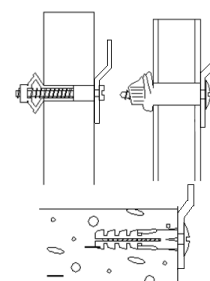
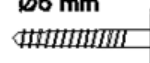

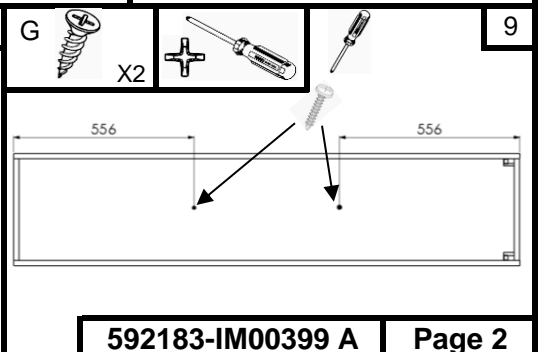
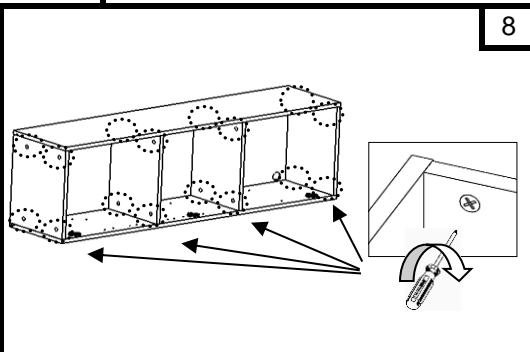
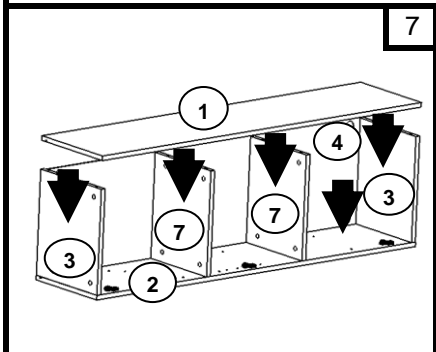
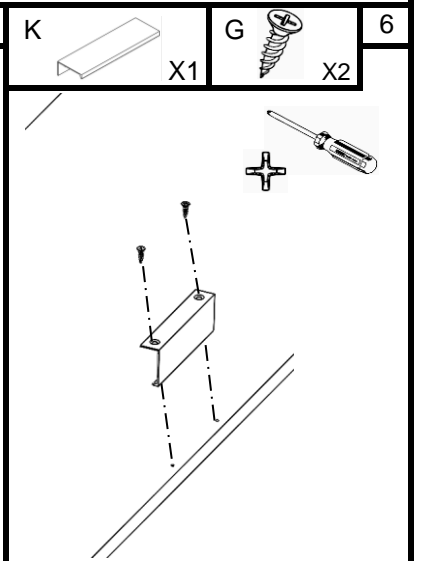
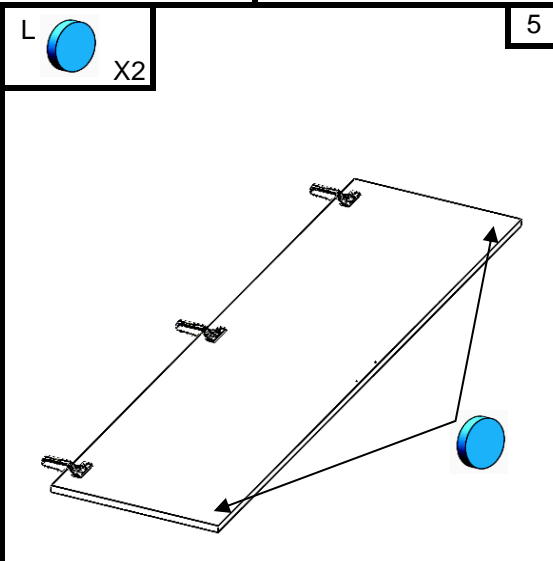
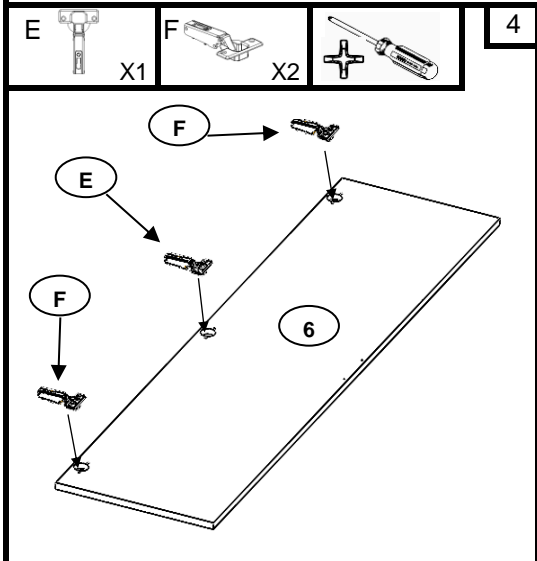
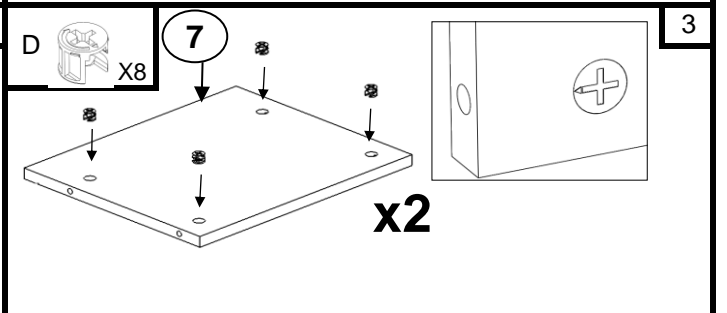
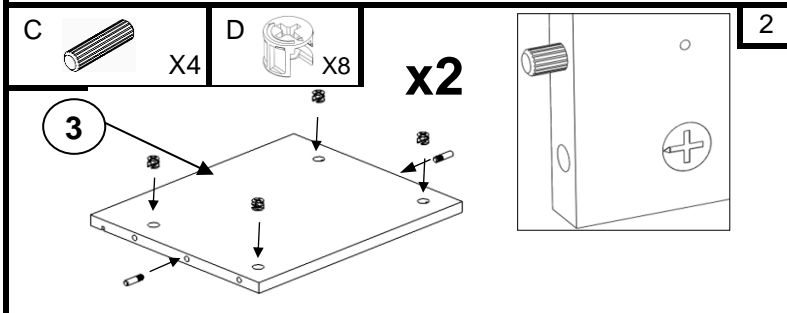
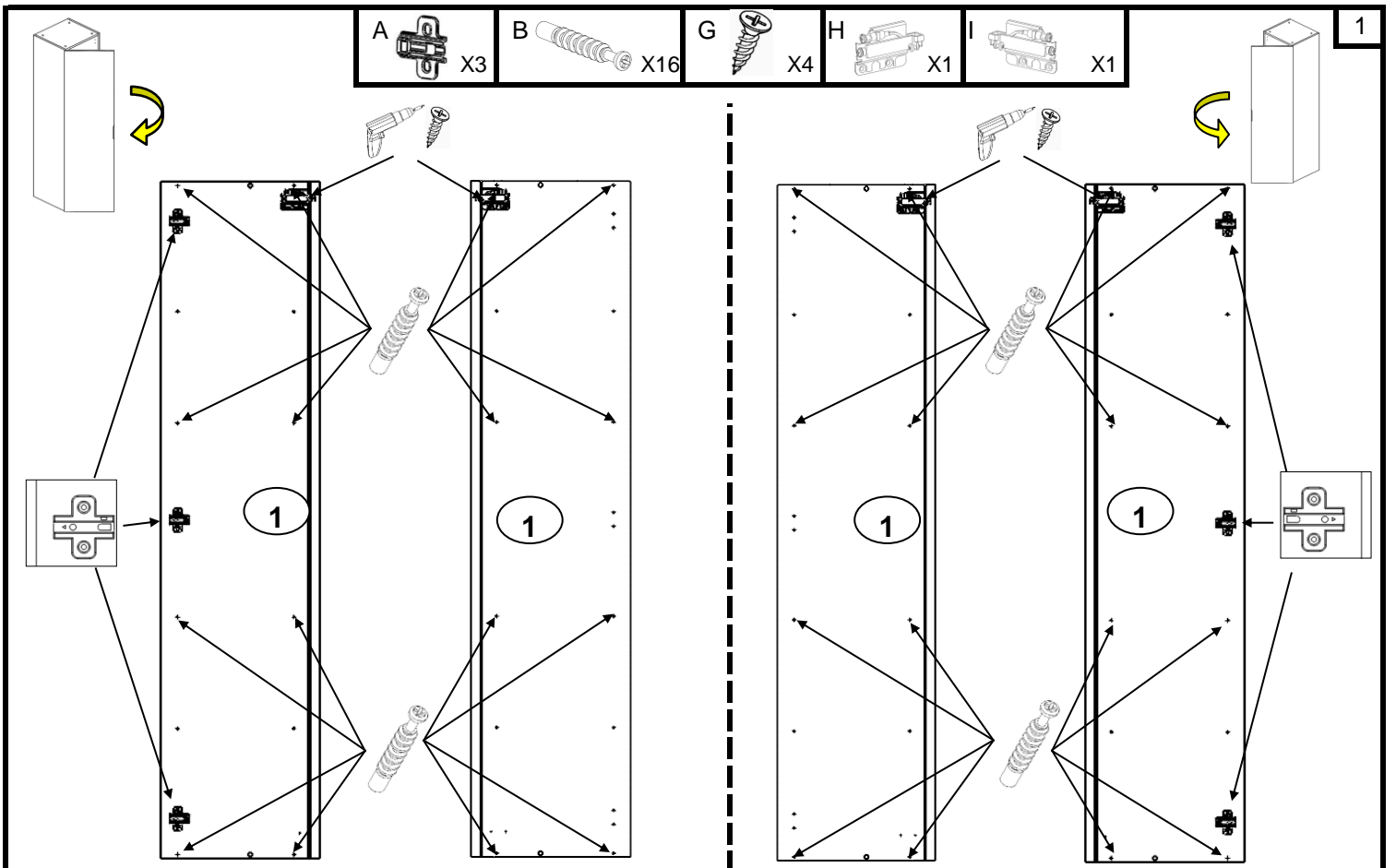

Colonne

Kolomkast - Column - Hoshschrank

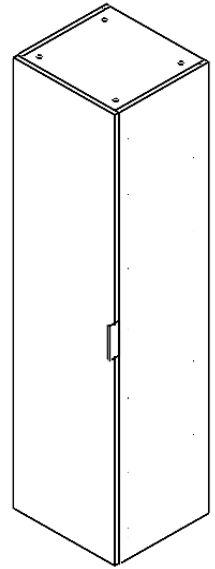
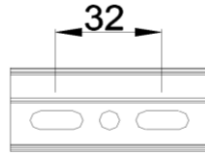
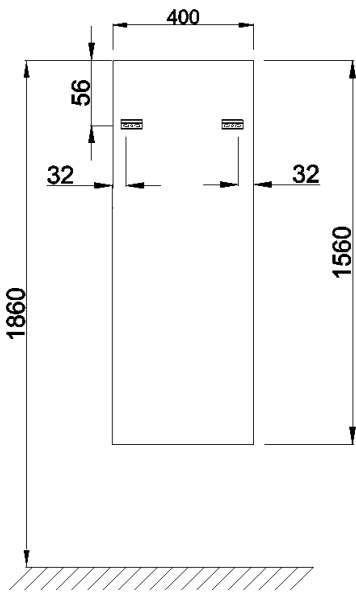

Démontage des portes

Demontieren deuren
Doors disassembling
Ausbau der Türen



FIXATIONS
Les fixations à utiliser sont en fonctions du mur;
elles ne sont pas livrées avec le meuble.

BEVESTIGINGEN
De te gebruiken schroeven en pluggen zijn afhankelijk van de muur
waarop het meubel wordt aangebracht en worden derhalve niet
meegeleverd.

FIXATIONS
The fixations to use depend of the type of support (wall) ; they are not
delivered with the furniture.

BEFESTIGUNGEN
Die zu verwendenden Befestigungen hängen von Ihrer Wand ab; Sie sind
nicht im Lieferumfang des Möbelstücks enthalten.
Eine unsachgemäße Befestigung der Wandbefestigung kann zur Ablösung
des Schränke aus der Wand führen. Benutzen Sie unbedingt Dübel, die in
Verbindung mit dem Wandmaterial die Tragfähigkeit sicherstellen. Sollten
Sie unsicher sein, welchen Typ Dübel und Schrauben Sie benötigen, fragen
Sie bitte beim Fachhandel nach.

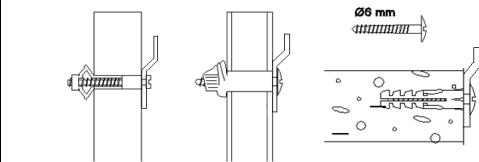

1

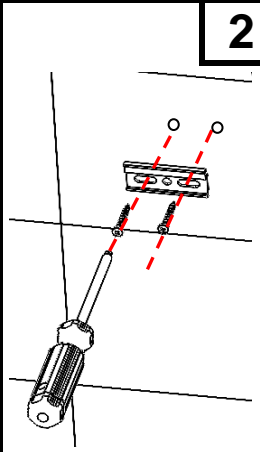

2

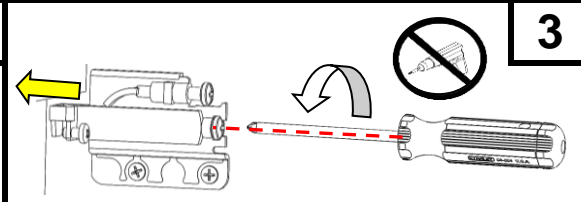

3

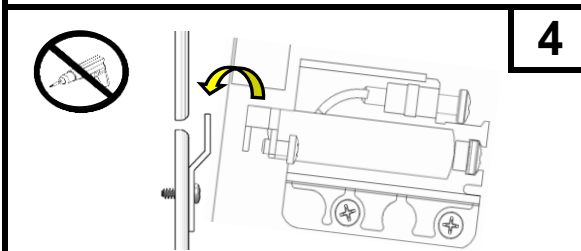

4

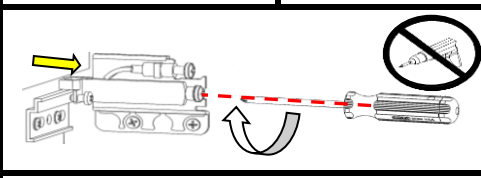

5

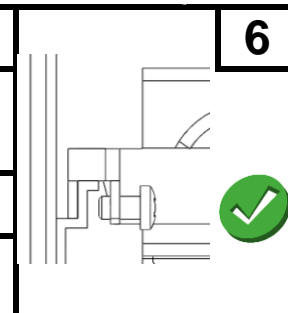

6

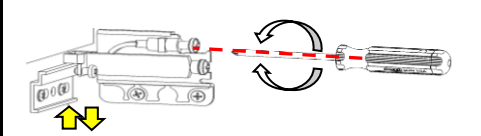

7

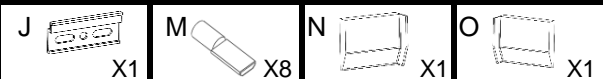

8

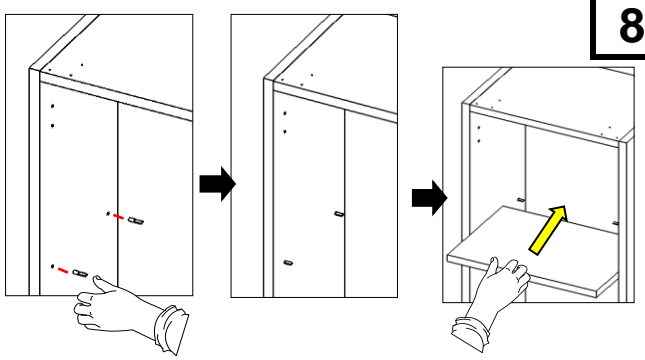

9

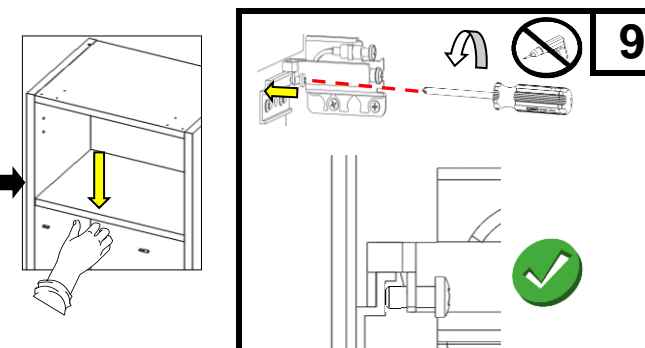

10

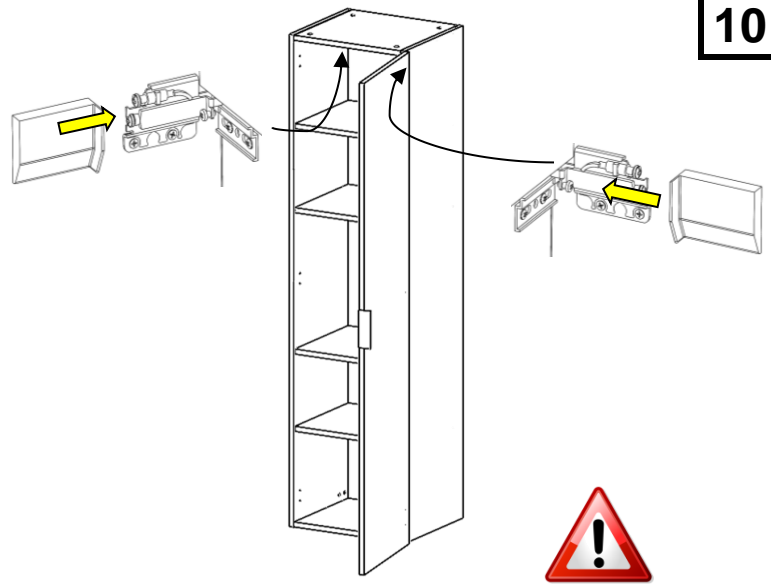

Montage des portes

Monteren deuren
Doors assembling
Montage der Türen

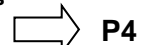

Réglage des portes

Afstellen deuren - Doors setting - Einstellen der Türen

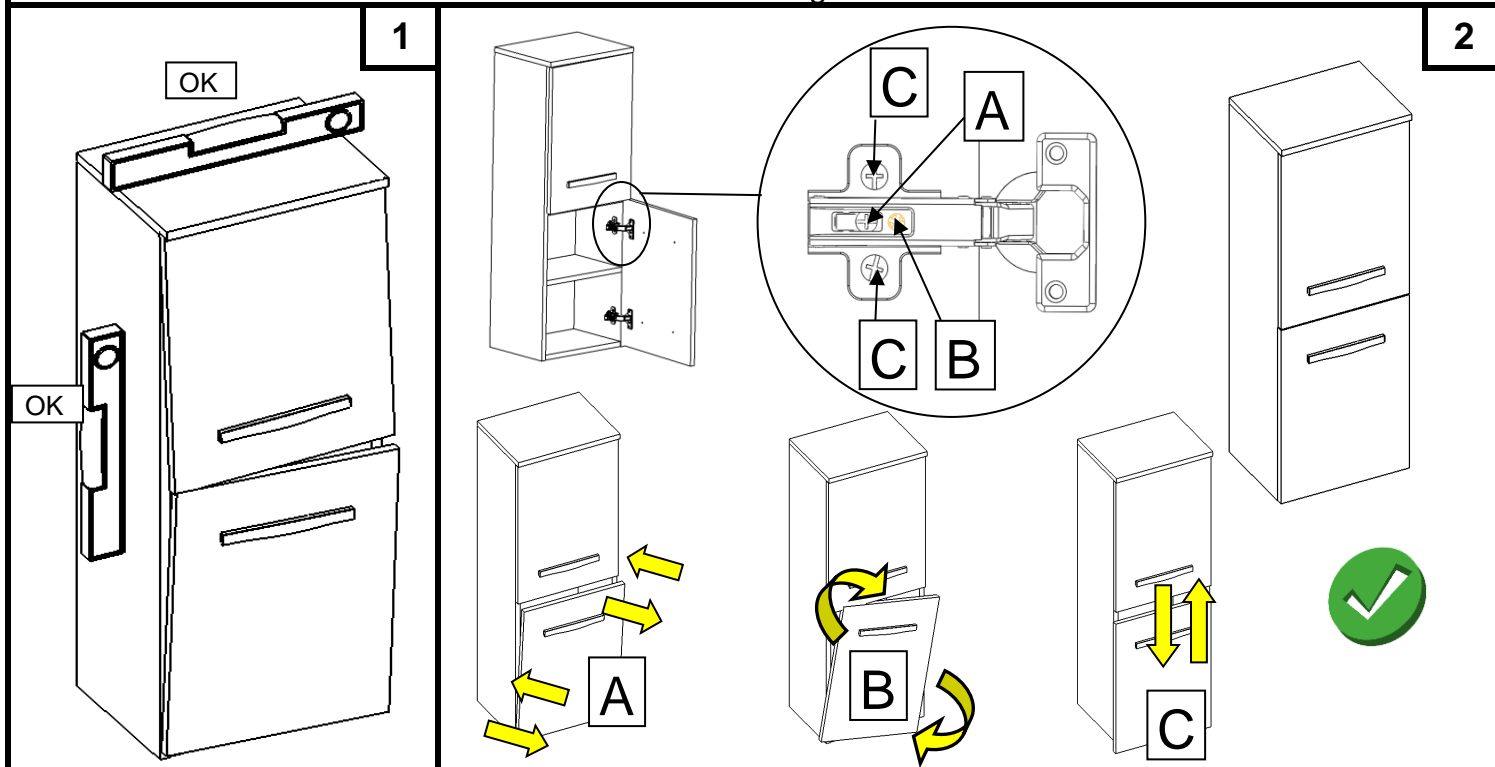

Démontage des portes

Demontieren deuren - Doors disassembling - Ausbau der Türen

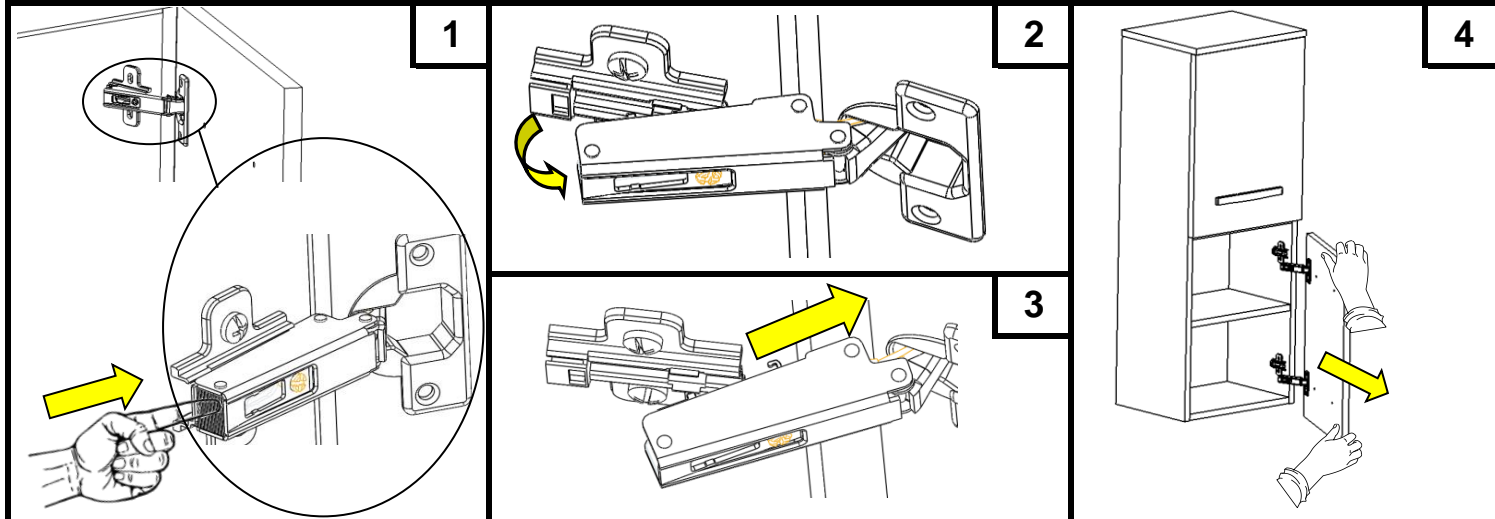

Montage des portes

Monteren deuren - Doors assembling - Montage der Türen

